

HÄNDLE disintegrators for crushing, milling  
and rough rolling of stiff to hard material  
up to Mohs hardness 3.

## Disintegrators

*WSL*

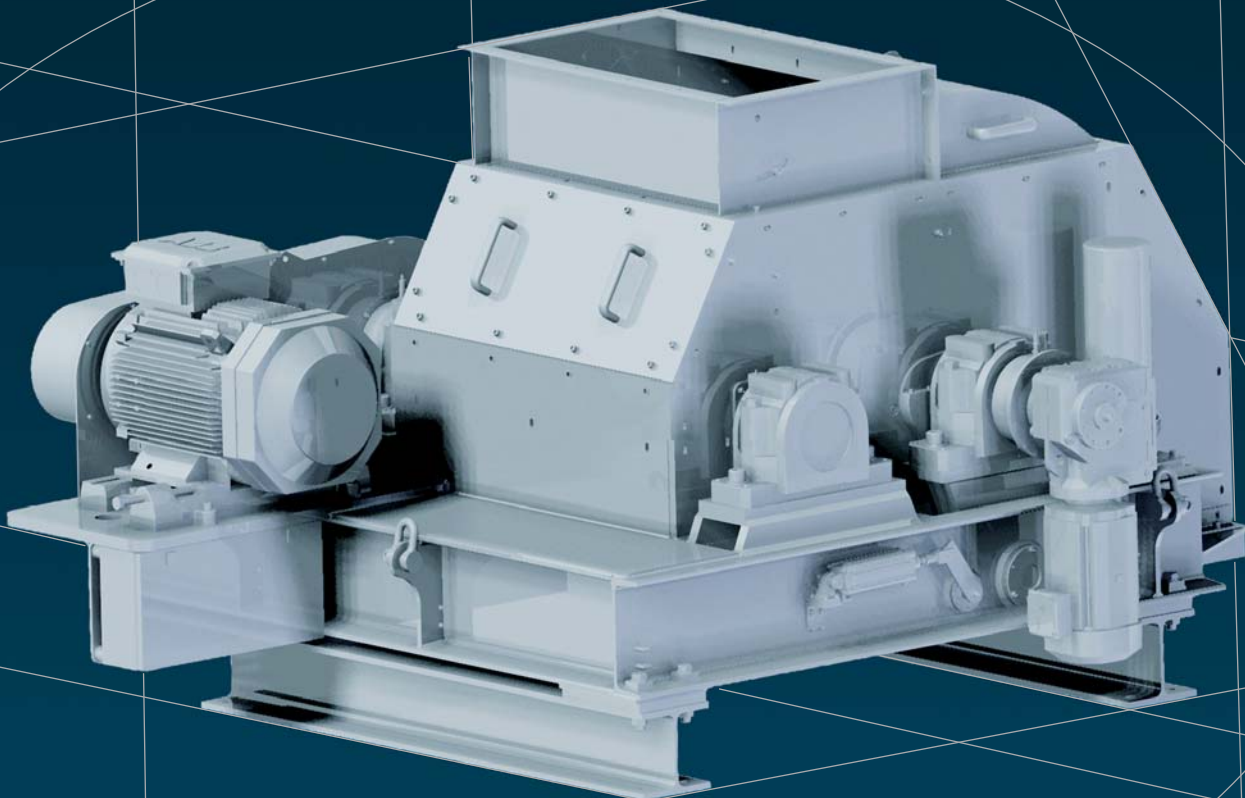

# The HÄNDLE disintegrator series

HÄNDLE has a number of different concepts to offer for the effective primary size reduction of ceramic raw materials. Disintegrators by HÄNDLE are used for crushing, comminuting and rough-rolling stiff to hard material up to Mohs hardness 3 while eliminating small rocks and pebbles that the clay may contain.

The disintegrator's impact, shear and compressive forces combine to achieve an extremely favorable conditioning and comminuting effect.

Available in three different sizes with roller widths of 800, 1000 and 1200 mm and throughputs of 65 to 100 m<sup>3</sup>/h compact (114 to 176 t/h wet).

## Defining characteristics

- Solid frame designed to serve simultaneously as supporting structure
- Overload protection by laminated springs incorporated into the end bearings of the rocker arms
- Feed roller fitted with rocker arms for gap adjustment between 5 and 25 mm
- Higher size-reduction ratio thanks to larger number of impact bars » superior product quality
- Elimination of hard foreign bodies



Impact roller with impact bars and heavy-duty wear plates

## Technical data

TYPE	Impact roller diameter / width mm	Feed roller diameter / width mm	Roller gap mm	Average final grain size <sup>1</sup> up to approx. mm	Volumetric throughput <sup>2</sup>		Power requirement <sup>3</sup> kW
					m <sup>3</sup> /h compact	t/h wet	
<b>WSL 480f</b>	450/ 800	800/ 800	5 - 25	50 x 30 x 15	65	114	45 / 5,5
<b>WSL 4100f</b>	450/ 1000	800/ 1000	5 - 25	50 x 30 x 15	80	141	55 / 5,5
<b>WSL 4120f</b>	450/ 1200	800/ 1200	5 - 25	50 x 30 x 15	100	176	75 / 5,5

Feedstock hardness: 3 Mohs, max. feed size: 300 mm

<sup>1</sup> Average final grain size as function of feedstock and roller gap

<sup>2</sup> Volumetric throughput and throughput capacity as functions of feed size, roller gap, type of feed, at normal speeds

<sup>3</sup> Power supply required as function of feedstock, feed size, roller gap, volumetric throughput and manner of feed

Subject to technical modification due to ongoing development.